



# ApplianceStor 85v2 & 180v2

High Performance Video Surveillance Appliance  
User Manual



## Copyright Notice

All rights, including copyright, in the content of this manual are owned or controlled by RASILIENT and protected by copyright. No part of this document may be photocopied, reproduced, or translated into another language without the prior written consent of RASILIENT Systems, Inc.

## Trademarks

All product names or brands mentioned herein are the trademarks of RASILIENT, its subsidiaries or other respective owners.

## Disclaimer

This manual provides information regarding set-up and installation of the product herein. Nothing herein may be construed as granting any right or license relating to any intellectual property rights of this manual or product. Unless otherwise provided in the Purchase and Sale Agreement for this product, manufacturer and distributor of this product will not be liable whatsoever relating to the distribution and/or use of this product. In addition, manufacturer and distributor of this product hereby specifically disclaim any express or implied warranties of merchantability, fitness for a particular purpose, or non-infringement of third party rights in connection with this product.

Manufacturer of this product has the right to change specifications and product descriptions at any time without notice.

# Table of Contents

<b>ABOUT THIS MANUAL</b> .....	<b>6</b>
CONVENTIONS.....	6
SAFETY SYMBOLS .....	6
SAFETY PRECAUTIONS.....	8
REGULATORY AND INTEGRATION INFORMATION .....	10
<b>INTRODUCTION</b> .....	<b>14</b>
AUDIENCE ASSUMPTIONS.....	14
ABOUT THIS GUIDE.....	14
PACKING CHECKLIST .....	14
SPECIFICATIONS .....	15
SYSTEM OVERVIEW .....	16
POWERFUL.....	16
RELIABLE .....	16
RIGHT SIZE .....	17
SSD DRIVES.....	17
OPTIMIZED.....	17
OPEN .....	17
SSD DRIVES.....	17
POWERFUL COMPACT DESIGN .....	17
UPGRADABLE .....	18
EASY .....	18
HOT-SWAPPABLE .....	18
MANAGEABLE .....	18
SYSTEM SPECIFICATION .....	19
<b>COMPONENT IDENTIFICATION:</b> .....	<b>21</b>
FRONT PANEL.....	21
FRONT PANEL LED INDICATORS.....	22
REAR VIEW.....	23
<b>RAIL KIT INSTALLATION:</b> .....	<b>24</b>

## List of Figures

Figure 1: AS85Rv2 .....	16
Figure 2: Front Panel Components .....	21
Figure 3: Front Panel LED Indicators .....	22
Figure 4: AS85v2 Blades (Rear View) .....	23
Figure 5: AS8Rv2 Blade .....	23

## List of Tables

Table 1: European Union Safety Requirements .....	11
Table 2: Packing Checklist.....	14
Table 3: Specifications.....	15

# About This Manual

**Conventions**

**Safety Symbols**

**Safety Precautions**

**Regulatory and Integration Information**

# About This Manual

## Conventions

To make sure that you perform certain tasks properly, take note of the following symbols used throughout this manual.



---

**Warning:** Provides Information to prevent injury in the process of completing a task.



---

**Caution:** Provides Information to prevent damage to the components in the process of completing a task.



---

**Important:** Provides Information required for completing a task.



---

**Note:** Provides Tips to aid in completing a task.

---

## Safety Symbols

The following symbols are placed on some components of the system to alert the user to potential hazards,



---

**WARNING:** Electric Shock Hazard – To reduce risk of injury from electric shock hazards, do not open this component.



---

**WARNING:** Contains No User or Field Serviceable Parts – To reduce the risk of injury from electric shock hazards, do not open this component.



---

**WARNING:** Hot Surface or Component - To reduce risk of injury from a hot component; allow the surface to cool before touching.

---



---

**WARNING:** Insert Network Interface Only - Any receptacle (e.g. RJ45) marked with this symbol indicates a network interface connection. To reduce the risk of electric shock, fire or damage to equipment, do not plug telephone or telecommunications connectors into this receptacle



---

**WARNING:** This symbol, on power supplies or systems, indicates that the equipment is supplied by multiple sources of power. To reduce the risk of injury from electric shock, remove all power cords to completely power down the system.



Weight in kg  
Weight in lb

---

**WARNING:** This symbol indicates that the component exceeds the recommended weight for one individual to handle safely. To reduce the risk of personal injury or damage to the equipment, observe local occupational health and safety requirements and guidelines for manual material handling.

---

## Safety Precautions



### Technician Notes

- Only authorized technicians should attempt to repair this equipment.
- Before installing this system, carefully read all the manuals included with the system.
- All repair procedures allow only module replacement. Because of the complexity of the individual boards and sub-assemblies, no one should attempt to make repairs at the component level or make modifications to any printed wiring board. Improper repairs can create a safety hazard.
- To reduce the risk of personal injury from electric shock and hazardous energy levels, do not exceed the level of repairs specified in these procedures.
- The system is designed to be electrically grounded. To ensure proper operation, plug the AC power cord into a properly grounded AC outlet only.



### Electrostatic Discharge Precautions

- Electrostatic discharge (ESD) can damage static sensitive devices or micro circuitry. Proper packaging and grounding techniques are required to prevent damage.
- Keep electrostatic-sensitive parts in their containers until they arrive at a static free work area.
- Use a wrist strap connected to the work surface as well as properly grounded tools and equipment
- Keep the area free of nonconductive materials such as ordinary plastic tools and foam packing.
- Avoid touching pins, leads, or circuitry.
- Always place drives with printed circuit board (PCB) assembly-side down.
- Grasp cards and boards by the edges. Hold drives by the frame. Avoid touching the solder joints or pins.
- If you need to lay the device down while it is out of the antistatic bag, lay it on the antistatic bag. Before picking it up again, touch the antistatic bag and the metal frame of the system unit at the same time.



### System Warnings

- Avoid dust, humidity, and extreme temperatures; place the system on a stable surface.
- To reduce the risk of personal injury from hot surfaces, allow the hot-plug disk modules and other system modules to cool before touching them.
- To reduce the risk of electric shock or damage to the equipment, do not disable the power cord grounding plug. The grounding plug is an important safety feature.



- Ensure the power cord is inserted into a grounded electrical outlet that is easily accessible at all times. Unplug the power cord from the power supply module to shut off power to the equipment
- Protect the storage system from power fluctuations and temporary power interruptions with a regulating uninterruptible power supply (UPS). This device protects the hardware from damage caused by power surges and voltage spikes and keeps the system operational during a power failure.
- The storage system must always be operated with all hot plug modules installed or slot covers in place to ensure proper cooling.
- Route power cords so that they will not be walked on or pinched by items placed upon or against them. Pay particular attention to the plug, electrical outlet, and the point where the cords exit from the product.

## Regulatory and Integration Information

### Regulatory Compliance Identification Numbers

For the purpose of regulatory compliance certifications and identification, this system is assigned a serial number. This system serial number can be found on the product label, along with the required approval markings and information. When requesting certification information for this product, always refer to this serial number. This serial number should not be confused with the marketing name or model number.

### Product Regulatory Compliance

#### Product Safety Compliance

Worldwide Safety approvals can be supplied upon request. Please contact your sales representative for approvals.

#### Product EMC Compliance

This product has been assembled from components that comply with the following electromagnetic compatibility (EMC) regulations.

#### Communications Commission Notice

Part 15 of the Federal Communications Commission (FCC) Rules and Regulations has established Radio Frequency (RF) emission limits to provide an interference-free radio frequency spectrum. Many electronic devices, including computers, generate RF energy incidental to their intended function and are, therefore, covered by these rules. These rules place computers and related peripheral devices into two classes, A and B, depending upon their intended installation. Class A devices are those that may reasonably be expected to be installed in a business or commercial environment. Class B devices are those that may reasonably be expected to be installed in a residential environment (for example, personal computers). The FCC requires devices in both classes to bear a label indicating the interference potential of the device, as well as additional operating instructions for the user.

The rating label on the device shows which class (A or B) the equipment falls into. Class A devices do not have an FCC logo or FCC ID on the label. Class B devices have an FCC logo or FCC ID on the label. Once the class of the device is determined, refer to the following corresponding statement.

## Class A Equipment

This equipment has been assembled with components that comply with the limits for a Class A digital device, pursuant to Part 15 of the FCC Rules. These limits are designed to provide reasonable protection against harmful interference when the equipment is operated in a commercial environment. This equipment generates, uses, and can radiate radio frequency energy and, if not installed and used in accordance with the instructions, may cause harmful interference to radio communications. Operation of this equipment in a residential area is likely to cause harmful interference, in which case the user will be required to correct the interference at personal expense.

## Declaration of Conformity for Products Marked with the FCC Logo—United States Only

This device complies with Part 15 of the FCC Rules Operation and is subject to the following two conditions: (1) this device may not cause harmful interference, and (2) this device must accept any interference received, including interference that may cause undesired operation. For questions regarding your product, please contact your sales representative.

To identify this product, refer to the Part, Series, or Model number found on the product.

## European Union Notice

Products with the CE Marking comply with both the EMC Directive (89/336/EEC) and the Low-Voltage Directive (73/23/EEC) issued by the Commission of the European Community. Compliance with these directives implies conformity to the following European Norms (items in brackets are the equivalent international standards):

**Table 1: European Union Safety Requirements**

EN55022 (CISPR 22)	Electromagnetic Interference
EN55024 (IEC61000-4-2,3,4,5,6,8,11)	Electromagnetic Immunity
EN61000-3-2 (IEC61000-3-2)	Power Line Harmonics
EN61000-3-3 (IEC61000-3-3)	Power Line Flicker
EN60950 (IEC950)	Product Safety

## Power Cords

The power cord set included in the system meets the requirements for use in the country where the system was purchased. If this system is to be used in another country, contact your sales representative to purchase a power cord that is approved for use in that country.

The power cord must be rated for the product and for the voltage and current marked on the product's electrical ratings label. The voltage and current rating of the cord should be greater

than the voltage and current rating marked on the product. In addition, the cross-sectional area of the wires must be a minimum of 1.00mm<sup>2</sup> or 18AWG, and the length of the cords must be between 1.8m (6 feet) and 3.6m (12 feet). If you have questions about the type of power cord to use, contact your sales representative.

# Introduction

**Audience Assumptions**  
**About This Guide**  
**Packing Checklist**  
**Specifications**  
**System Overview**

# Introduction

## Audience Assumptions

This manual assumes that you are a service technician or network administrator familiar with computer hardware, data storage and network administration terminology and tasks.

## About this Guide

AS85V2 comes with appropriate hardware installed. User only needs to configure IP addresses, install appropriate VMS software to administer and view the cameras. This manual is generally organized as follows:

## Packing Checklist

Make sure you have all the components shipped with your system. If any item is damaged or missing, please contact your sales representative for replacement. The AS85V2 is shipped with the following:

**Table 2: Packing Checklist**

<b>Chassis</b>	2U Enclosure
<b>Solid State Disk Drives</b>	Up to two per blade depending upon configuration
<b>Power Cords</b>	Two Power Cords
<b>Server Blades</b>	Four

## Specifications

The table below is the technical specification for the AS85V2.

**Table 3: Specifications**

<b>Dimensions</b>	Height: 3.4" / 88mm Width: 17.3" / 444mm Depth: 31.5" / 800mm
<b>Weight</b>	Max-weight: 63 lbs / 29 kg ±5%
<b>Temperature</b>	Operating System: +10°C~+35°C Non-operating System: -40°C~+70°C
<b>Humidity</b>	Operating System: 20%~80% Non-operating System: 10%~95%
<b>Power</b>	➤ 100--240Vac input, 50/60Hz
<b>Current</b>	➤ 100-140Vac, 12.9A, 50-60Hz, 1000 Watts Max ➤ 200-240Vac, 9.5A, 43-63Hz, 1600 Watts Max

## System Overview

The ApplianceStor 85Rv2 is a modular server system which packs four high performance server modules in a single 2U rack mount platform providing unmatched performance and density. Each module can be used to integrate VMS (Video Management Software), failover, archive, administration and access control servers in a single high density 2U system. The AS85Rv2 is ideally suited for use in conjunction with the PS5000to provide a simple to use, high performance, and large capacity video surveillance solution. Significantly reduces the cost over a separate VMS servers, reduces cabling and the nightmare of integrating VMS, OS, commodity server and storage, while significantly reduces the overall solution cost. AS85Rv2 is prequalified and provides guaranteed performance with all major VMS solutions.

Powerful



Figure 1: AS85Rv2

AS85Rv2 packs four powerful server modules into single 2U system. Each module is built around two high performance Intel® Xeon Scalable 4208 or 4110 (eight cores 16 threads) server class processors with up to 2.1 GHz clock speed and DDR4 2666 MHz ECC memory. Each AS85Rv2 module offers high performance and bandwidth connectivity to meet the requirements of the most demanding megapixel camera applications. Each AS85Rv2 server module delivers unmatched LAN connectivity with three GbE ports and an additional port that is dedicated to management for a total of four GbE LAN ports. Optionally, the data LAN ports can be increased to six GbE ports per blade.

Reliable

The AS85Rv2 provides dual, redundant power supplies. It uses ECC RAM and it guarantees that video being stored, read, and transferred is always correct. It uses a parity bit to accomplish the data protection. Most NVRs and DVRs are not protected to this level and with these products, crucial video can be lost.



## Right Size

The AS85Rv2 is designed for large megapixel deployments and perfectly matched with the high capacity and performance PS5000 IP Storage system. The AS85Rv2 when used with PS5000, can scale capacity up to 5.8 PB. The AS85Rv2 provides unmatched performance density to ensure optimal, cost effective, and dependable video storage

## SSD Drives

SSD drives are designed to deliver reliable 24×7 operation and optimized for power consumption, quiet operation, and video. This ensures the highest video storage performance, with enterprise-class reliability and a significant system cost savings.

## Optimized

Designed and optimized for video surveillance. It delivers the demanding performance for the most demanding megapixel installations.

## Open

Purpose built open platform to integrate Video Management Software. We have prequalified all major OS and VMS providers. We continually add more to ensure the widest possible certification coverage.

## SSD Drives

Designed for 24/7/365 operation. We use SSD drive technology to provide the performance and reliability need for the most demanding video surveillance deployment.

## Powerful compact design

Packs four high performance enterprise class servers into a single 2U rack mountable chassis. It offers market leading density and performance to deliver a unique, compact video surveillance solution.

## Upgradable

AS85Rv2 provides an expansion slot for future expansion. Additional RAM can be added, up to 32GB of RAM.

## Easy

The AS85Rv2 delivers effortless installation, management and administration. All administration functions assume technicians have basic to no storage knowledge. Once racked, setup time should be 15 minutes or less.

## Hot-swappable

The AS85Rv2 features two 2.5" hot-swappable SSD drives per blades and power supplies for easy installation and maintenance.

## Manageable

Very easy to manage with an optional web-based remote management, GUI-driven iKVM. The upgrade kit provides full control of server functions with dedicated hotkeys and remote server screen. Virtual media-over-LAN helps share local devices with target servers, enabling fast troubleshooting.

## System Specification

<b>Core Technology</b>	
CPU Type	Dual Intel Xeon 3104 (180v2) / 4110 (85v2)
Socket	2 x Socket LGA3647
Core Logic	Intel® C621 PCH Chipset
Bench Mark/Clock speed	16472/2.1 GHz
Memory size	16GB (expandable up to 64GB)
Memory type	DDR4 2133 ECC RDIMM
Video Storage Performance	Up to 120Mbps /15MBps internal and 720Mbps / 90MBps with PS5000
<b>Expansion</b>	
Expansion Slot	1 (only available on the non-RAID recording server model)
Slot Type	1x PCI-E x16
<b>Storage</b>	
HDD Bays	2 x Hot-swap 2.5" per blade
Drive support	2, 3, 4, 6, 8, 10, 12 and 14TB SATA III Video Class
	SSD for OS
RAID	1
<b>Networking</b>	
Data Ports	4 x GbE
Management	1 x GbE
<b>Display Outputs</b>	
Onboard Graphic	ASPEED AST2500 with 64MB VRAM
Optional HD Graphic	HD 7750 1 GB DDR3 plus mDP, 2x HDMI (DVI and VGA via adapters) (not available with all configurations)
Opt Graphic performance	1631
Max Supported Resolution	DVI - 1920x1200 @ 60Hz
	HDMI - 4096x2160 @ 24Hz
	mDP - 4096x2160 @ 60 Hz
<b>I/O Ports</b>	
	2 x USB 3.0 (rear)
	1 x D-Sub (VGA) (1x rear)

<b>Compliance</b>	
Safety	US/Canada (UL1950-CSA950)
	Europe (CE, EN55022 compliance to EU Directive 89/366/EEC& TUV)
EMI	US (FCC , CFR47 Part 15, Class A)
	Europe (CE, EN55022 class A & EN55024)
	Australia (C-TICK), Taiwan (BSMI)
<b>Physical Characteristics</b>	
Dimensions (in./mm)	31.5" x 17.3" x 3.4" / 800 x 444 x 44 mm
Weight	63 lbs. /29 Kg (max)
<b>Power</b>	Dual redundant 1+1
Voltage	100 - 240 V <sub>AC</sub> Dual redundant 1+1
Watts	1000/1600 W 80 PLUS Gold 100 - 240 V <sub>AC</sub>
<b>Operating Environment</b>	Designed for 24x7x365
Operating temperature	10°C ~ 35°C
Non operating temperature	-40°C ~ 70°C
Humidity	20% ~ 90% ( Non condensing)
Operating altitude	0 to 10,000' / 0 to 3000m 20% ~ 90%

# Component Identification

## Component Identification:

### Front Panel

Following figure shows each front panel component:

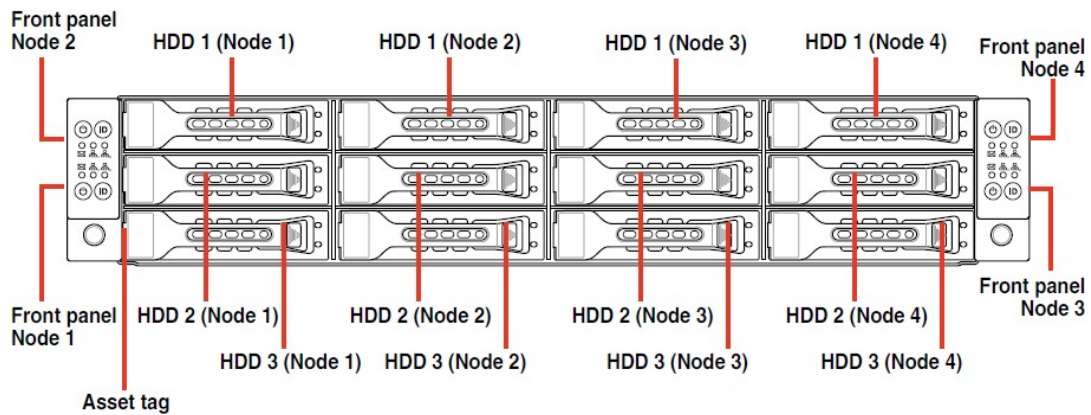
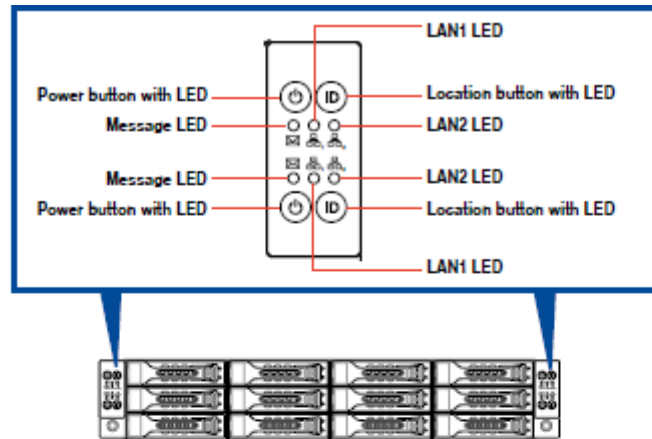

Figure 2: Front Panel Components

## Front Panel LED Indicators



LED	Icon	Display status	Description
Power LED	💡	ON	System power ON
Message LED	✉	OFF	System is normal; no incoming event
		ON	A hardware monitor event is indicated
LAN LEDs		OFF	No LAN connection
		Blinking	LAN is transmitting or receiving data
		ON	LAN connection is present
Location LED	ID	ON	Location switched is pressed
		OFF	Normal status. (Press the location switch again to turn off.)

Figure 3: Front Panel LED Indicators

## Rear View

Following diagram shows the location of all the rear I/O ports on AS85V2 blades. Power Supplies are also shown.



Figure 4: AS85v2 Blades (Rear View)

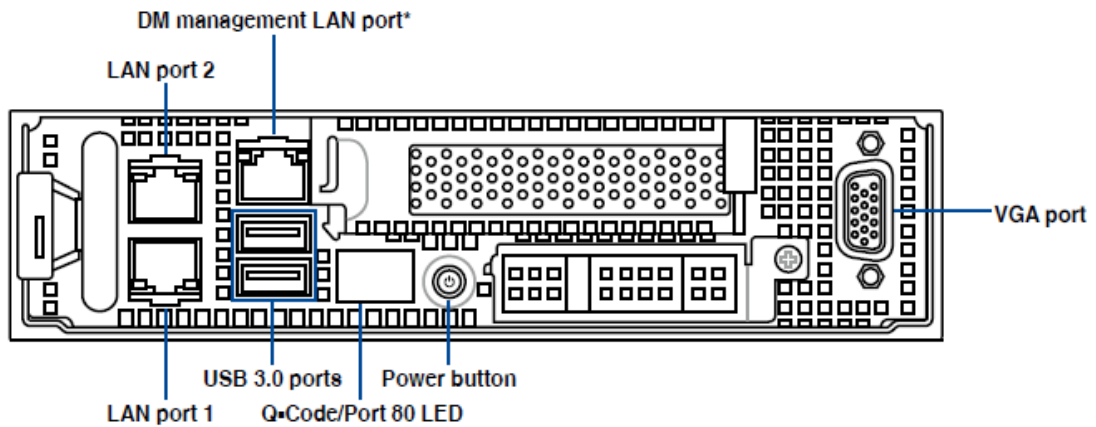

Figure 5: AS8Rv2 Blade

# Rail Kit Installation

## Rail Kit Installation:



The tool less design of the rail kit allows you to easily install the rack rails into the server rack without the need for additional tools. The kit also comes with a metal stopping bracket that can be installed to provide additional support and stability to the server.

The tool-less rail kit package includes:

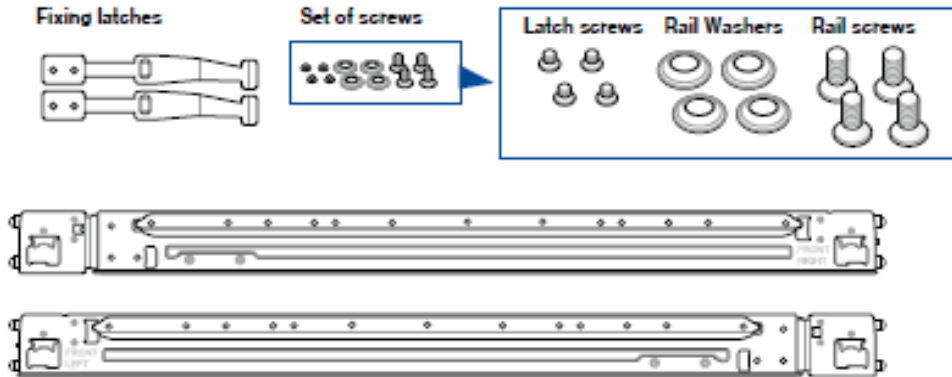

### Installing the tool-less rack rail

To install the tool-less rack rails into the rack:

1. Secure the two fixing latches to the two sides of the server using the set of latch screws.



The locations of the screw holes vary with different server models. Refer to your server user manual for details.

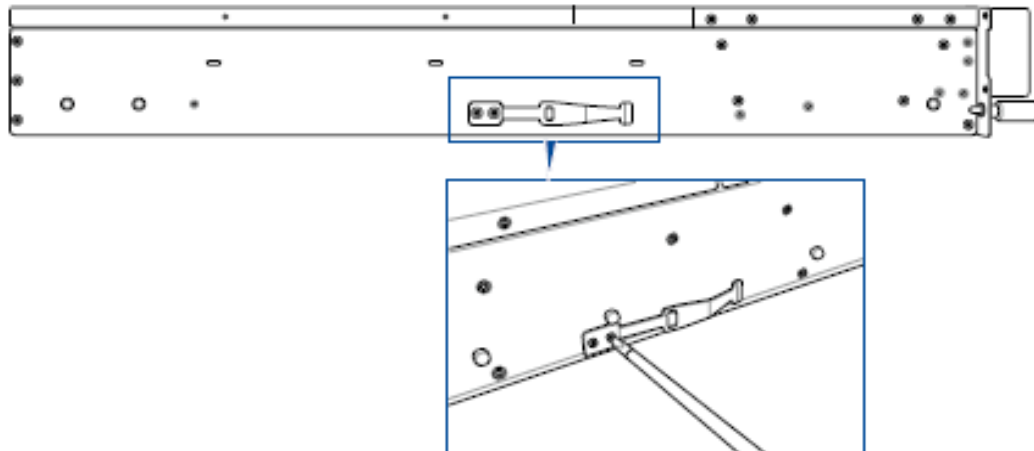

2. Select a desired space and place the appropriate rack rail (left and right) on opposite positions on the rack.



---

A 1U space consists of three square mounting holes with two thin lips on the top and the bottom.

---



3. Press the spring lock then insert the studs into the selected square mounting holes on the rack post.
4. Press the spring lock on the other end of rail then insert the stud into the mounting hole on the rack post. Extend the rack rail, if necessary.
5. (Optional) Use the rail screw and rail washer that comes with the kit to secure the rack rail to the rack post.
6. Perform steps 3 to 5 for the other rack rail.



---

Ensure that the installed rack rails (left and right) are aligned, secured, and stable in place.

---

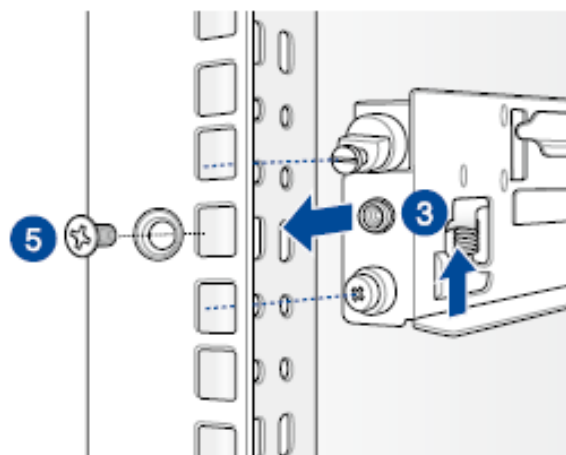

7. Lift the server chassis and insert into the rack rail.



- 
- Ensure that the rack rail cabinet and the rack posts are stable and standing firmly on a level surface.
  - We strongly recommend that at least two able-bodied persons perform the steps described in this guide.
  - We recommend the use an appropriate lifting tool or device, if necessary.
- 



---

Ensure to include the side knots on the two sides of the server in the rack rail holders.

---



---

The illustrations shown above are for reference only.

---